

Optimizing TEC PID Coefficients Automatically with the Model 2510-AT Autotuning TEC SourceMeter® Instrument

Introduction

Many thermoelectric cooler (TEC) controllers use PI or PID (proportional, integral, derivative) loops for temperature control. While these loops can provide precise temperature control, they require proper values for each P, I, and D term. Many times, these terms are established through trial and error, which is time consuming, difficult, and may result in longer than necessary temperature settling times. In a production test environment, this difficulty is multiplied if several temperature setpoints or different devices must be evaluated on a routine basis.

What is Autotuning?

Autotuning provides an automated way to determine good values for each term in the Model 2510-AT TEC SourceMeter Instrument's temperature control loop for TEC devices. The autotune process is performed once for each desired system setpoint. The 2510-AT autotune algorithm applies a voltage step function across the TEC or Peltier device. Information from the temperature response of the system is extracted and applied to a modified version of the Ziegler-Nichols tuning technique, providing two sets of PID coefficients. One set is optimized for minimum temperature overshoot, while the other is optimized for minimum settling time. Either set may be chosen for use, depending on test requirements or device limitations. If desired, these numbers may also be used as starting points when fine-tuning the system response.

The Model 2510-AT's autotune algorithm assumes that the system response to a step function in the Peltier voltage is an exponential temperature rise of the form:

$$T_{\text{system}} = T_{\text{initial}} \text{ for } t < t_{\text{Lag}}$$

$$T_{\text{system}} = T_{\text{initial}} + T_{\text{step}} (1 - e^{-(t-t_{\text{Lag}})/\text{Tau}}) \text{ for } t \geq t_{\text{Lag}}$$

This is depicted graphically:

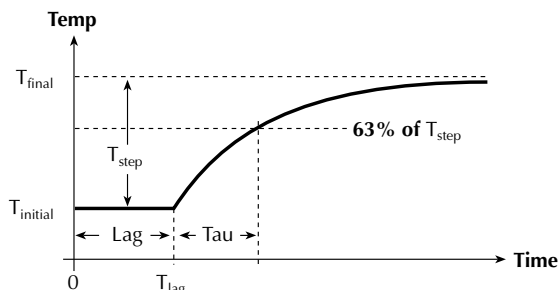

Figure 1. Temperature step for Ziegler-Nichols tuning method.

In this case, the temperature step is shown as being positive, but it could also be a negative step. The exponential response is typical for most TEC (Peltier) controlled laser diodes and fixtures. Temperature responses of a different mathematical model will cause the autotune function to fail (or give unpredictable results). Once the Lag and Tau times are extracted from the sampled data taken from the voltage step response, the tuning constants are calculated. See the section titled "Typical Sources of Error" for the limitations of the algorithm. See Chapter 4 in the Model 2510 User's Manual for a discussion of PID concepts.

Test Description

The system Tau is a measure of how quickly the system (2510 + TEC + fixture + device) can reach a given temperature. To permit the autotune algorithm to tune the widest possible range of devices, an initial value for the system Tau must be determined. The system Tau can range from three to 30 seconds for a laser diode module to more than 300 seconds for a larger fixture.

Laser Diode Modules

The autotune algorithm was designed to determine good PID coefficients for TEC-equipped Laser Diode Modules (LDMs) designed for communications. These LDMs typically have a short Tau, so autotuning takes from five to 15 minutes.

Test Fixtures

In addition to LDMs, the autotune algorithm has settings that permit tuning test fixtures, which have much longer system Tau values. When tuning test fixtures, the system Tau must be set to a range similar to the actual system Tau. If the actual system Tau is unknown, set the Tau to "medium" and if autotuning is not successful, use a long Tau setting and attempt autotune again.

Autotune Process

When completed, the autotune algorithm supplies two sets of PID values: minimum overshoot and minimum settling time. The minimum overshoot set protects the DUT from thermal damage, and is useful for temperature setpoints near the maximum specified temperature of the DUT (Figure 2). For setpoints that do not approach the maximum specified temperature, the minimum settling time PID set can be used to decrease the settling time (Figure 3). Figures 2 and 3 show an example of a laser diode

module using a 3°C temperature step (from 22.5°C to 25.5°C). The settling time for the minimum overshoot response is about twice as long as the minimum settling time response.

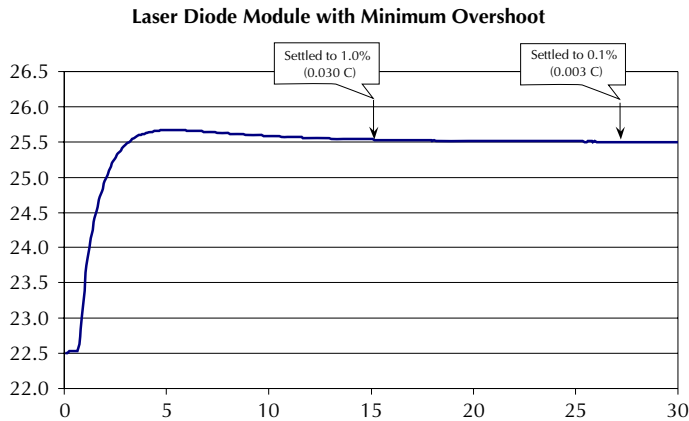

Figure 2. Minimum Overshoot
 Settled to $\pm 1.0\%$ ($\pm 0.030^\circ\text{C}$) in 15.32 Seconds
 Settled to $\pm 0.1\%$ ($\pm 0.003^\circ\text{C}$) in 27.32 Seconds

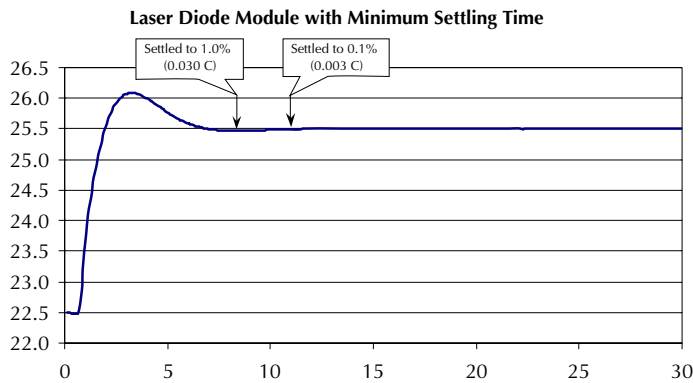

Figure 3. Minimum Settling Time
 Settled to $\pm 1.0\%$ ($\pm 0.030^\circ\text{C}$) in 8.54 Seconds
 Settled to $\pm 0.1\%$ ($\pm 0.003^\circ\text{C}$) in 11.14 Seconds

The time required to complete an autotune procedure depends on the thermal characteristics of the DUT (TEC cooling/heating power, thermal mass), ambient temperature, and the temperature step start and stop settings. However, five minutes is a rough estimate for a typical laser diode module.

The start and stop temperature for the autotune temperature step must be supplied before invoking autotune. It is also necessary to set the protection limits for temperature (LOLIM and HILIM) as well as the maximum voltage and current that the TEC can accommodate. All six values must be entered before the autotune will be allowed to run. Note that the autotune process is for temperature-based control ONLY. The start temperature for the autotune procedure is simply the beginning temperature for the step. The stop temperature for autotune is the desired temperature setpoint or the desired operating temperature for the laser or fixture.

The 2510-AT displays five status messages during the autotune process:

- **Measuring System Temp**—The 2510-AT applies 0V to the output and checks for a constant fixture+DUT temperature. The autotune algorithm assumes that when it is invoked, the system temperature has already stabilized to the zero voltage/non-excited steady state.
- **Applying Initial Step**—During this step, a preliminary set of PID values is determined.
- **Seeking Prog Stop Temp**—Proper voltage setting is determined for the stop temperature.
- **Seeking Prog Start Temp**—Proper voltage setting is determined for the start temperature.
- **Applying Final Step**—Autotune temperature step is applied, with the extracted results being applied to the Ziegler-Nichols algorithm, creating the two sets of PID coefficients.

The progress indicator, located in the lower right corner of the instrument display, shows whether or not the autotune process is active.

Test System Configuration

Connect the TEC portion of the Device Under Test (DUT) as shown in **Figure 4**. See the “Methods and Techniques” section for cabling resistance requirements.

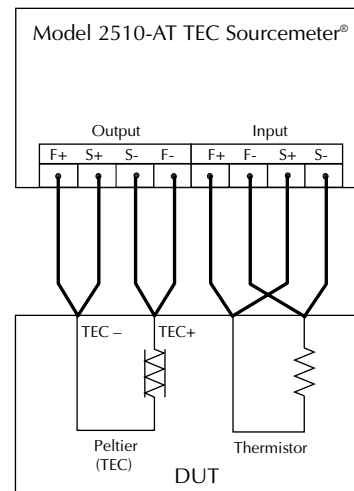

Figure 4. 2510 to DUT (TEC) connections (4-wire sensor shown).

Note that the Model 2510 assumes that a positive current heats the DUT. Many laser diode TEC applications assume that a positive current cools the DUT; therefore, swap the + and – output lead connections for applications where a positive current cools the DUT (as shown in **Figure 4**). The swap has no negative effect on the 2510 or TEC performance.

The 4-wire mode is required for the output and is recommended for the input (temperature sensor) when using a thermistor or RTD for best accuracy. For the input connections, 2-wire mode (no sense connections) is used for solid-state sensors (e.g., AD590, LM335).

The autotune feature can only be activated remotely, via the GPIB or RS-232 ports, so a computer and the appropriate accessories (cable or GPIB card and cable) are required, as outlined in the section titled "Equipment List."

SCPI Programming

1. Set protection limits for the TEC (Peltier device), autotune parameters, and start autotune session:

```
'Reset instrument
send (kth2510AT, "*rst", status)          'reset TEC controller
'Set temperature transducer to thermistor and 4-wire sense mode
send (kth2510AT, ":sens:temp:tran ther", status) 'select thermistor
send (kth2510AT, ":sens:temp:ther:rang le4", status) '10 kOhm thermistor
send (kth2510AT, ":syst:rsen on", status) '4-wire mode enabled
'Set voltage limit
send (kth2510AT, ":sour:volt:prot 9.5", status) '+9.5V limit
'Set current limit
send (kth2510AT, ":sens:curr:prot 2.5", status) '2.5A limit
'Set temperature limit*
send (kth2510AT, ":sour:temp:prot:high 75", status) '75C max temp
send (kth2510AT, ":sour:temp:prot:low 15", status) '15C min temp
send (kth2510AT, ":sour:temp:prot:state ON", status) 'enable temp 'protection (default)
'Configure 2510 to set SRQ upon Autotune completion
send (kth2510AT, "*ese 16", status) 'Mask autotune error bit
send (kth2510AT, "stat:oper:enab 128", status) 'Mask autotune success bit
send (kth2510AT, "**SRE 1", status) 'Mask meas summ. bit for SRQ
send (kth2510AT, "*cls", status) 'Clear status registers/queue
'Set Autotune system tau (thermal response time), use "short" for laser diode modules, for fixtures start
'with "med" then try "long" if medium does not tune
send (kth2510AT, ":sour:temp:atun:systau short", status) 'System Tau=short
'Set Autotune temperature step: start and target (stop) temperatures
'Note: minimum step is 3C, may be positive or negative step
send (kth2510AT, ":sour:temp:atun:start 25", status) '25C start temp
send (kth2510AT, ":sour:temp:atun:stop 30", status) '30C temp setpoint
'Activate Autotune function
send (kth2510AT, ":sour:temp:atun:init", status) 'begin Autotune
'Loop (wait) until SRQ, or skip below code and use front panel notification
Loop Until srq 'SRQ cmd is GPIB-controller specific
spoll(kth2510AT, poll, status) 'Clear SRQ bit
```

2. After the autotune process is complete, the status (complete or error) will be displayed briefly. See "Error Messages" for SCPI programming to retrieve the autotune status. After a successful autotune session, the two sets of PID values are available. To use the new PID set, see step 3. It is also possible to view the autotune PID sets by retrieving them from the instrument:

```
'Retrieve the Minimum Settle Time (mset) PIDs, replace mset with mov for Minimum Overshoot PID retrieval
send(kth2510AT, "sour:temp:atun:lcon:mset:gain?", status) 'Query mset P
enter(strMSETP, 10, length, kth2510AT, status) 'Retrieve mset P
send(kth2510AT, "sour:temp:atun:lcon:mset:int?", status) 'Query mset I
enter(strMSETD, 10, length, kth2510AT, status) 'Retrieve mset I
send(kth2510AT, "sour:temp:atun:lcon:mset:der?", status) 'Query mset D
enter(strMSETI, 10, length, kth2510AT, status) 'Retrieve mset D
```

3. A successful autotune session results in two sets of PID values. To use a set of autotune PID values, transfer the desired set to the active PID set. Note that the autotune results are stored in volatile memory and are erased by an instrument reset or power cycle. See step 7 for a method to save the desired PID set.

3.1 Use minimum temperature settling time PID coefficients:

```
'Use PID values for minimum settling time
send (kth2510AT, ":sour:temp:atun:lcon:mset:tran", status) 'select & use min settle time values
```

3.2 Or, use the minimum overshoot response:

```
'Use PID values for minimum temperature overshoot
send (kth2510AT, ":sour:temp:atun:lcon:mov:tran", status) 'use min overshoot PID
```

4. After choosing the PID values, program the setpoint and setpoint tolerance:

```
'Set setpoint temperature
send (kth2510AT, ":sour:temp:spo 30", status)           '30C temp setpoint
'Set temperature setpoint tolerance, percentage of entire temp range (275C)
send (kth2510AT, ":sour:stol:perc 0.001", status)      '0.1% tolerance window
send (kth2510AT, ":sour:stol:coun 10", status)         '10 consecutive points within
                                                         window to be considered within temp
```

5. The Fahrenheit temperature scale may be used instead of Celsius ($^{\circ}\text{C}$ is the default):

```
'Set temperature units to F
send (kth2510AT, ":unit:temp F", status)               'Use Fahrenheit
```

6. Now, the Model 2510-AT is ready to control temperature. Initiate the control loop by pressing the ON/OFF key on the front panel or initiate it remotely by using this command:

```
'Set temperature control ON
send (kth2510AT, ":outp on", status)                   'Turn output ON
```

7. If the PID coefficients provide acceptable performance, save the settings in the Model 2510-AT's non-volatile memory:

```
'Save Instrument setup
send (kth2510AT, "**sav 0", status)                     'Store instrument setup in memory location 0
```

8. The Model 2510-AT can be configured to power-on with the saved configuration:

```
'Set power-on default
send (kth2510AT, ":syst:pos 0", status)                 'Power-up to setup saved in memory loc 0
```

Methods and Techniques

Cabling

The maximum sense lead resistance is 1Ω for each sense lead. The maximum force lead resistance is 0.1Ω . Force cabling with resistance higher than this maximum value can cause instability in the PID loop or an apparently false voltage limit indication (V_{lim}). The warning appears to be false because the output voltage at the TEC will be less than V_{lim} , but adding the cable IR voltage drop means that V_{lim} is exceeded on the output force cable ends nearest to the Model 2510-AT.

TEC Characteristics

The gain of a Peltier varies with operating temperature and increases with increasing temperature. This variation can be as much as 7-to-1 over the Peltier's operational temperature range. This change in operational efficiency is largely due to the fact that the I^2R heating generated by the normal operation of the Peltier Junction *adds* to the efficiency of the junction when pumping heat into the load, but *subtracts* from the efficiency of the junction when cooling the load. This change in Peltier gain will cause the overall system characteristics (and hence, the tuning constants that will control it) to change appreciably over the entire operating temperature range of the system. This is why it's important to tune the PID loop at the system's actual operating temperature. Ideally, if a setpoint changes by more than 10°C , a new set of tuning constants should be generated to control it. These new constants can be written into the registers of the

Model 2510-AT "on the fly" via GPIB commands before issuing the new temperature setpoint.

Performing consecutive autotune procedures on a TEC will not provide identical PID coefficients. That's because the initial conditions for the TEC will not be identical from run to run. Each run in consecutive autotune procedures will have different initial temperatures for the DUT, TEC, and heat sink. These differences are sufficient to produce unique PID values.

Multiple Setpoints with One Set of PID Values

If a single set of PID values will be used for more than one temperature setpoint, use the higher temperature setpoint for the autotune stop temperature. Using the higher temperature setpoint will incorporate the higher inherent gain of the TEC, resulting in a lower P value. Using PID values determined at a lower temperature setpoint at a much higher temperature setpoint may result in oscillation or system instability, due to the higher gain of the TEC at higher temperatures. Averaging the constants from both extremes is not advisable because of poor performance at both operating points – more overshoot and ringing at high temperatures and a slower response at lower temperatures.

Large Temperature Steps

If a protection limit (current, voltage, or temperature) is exceeded during the autotune process (specifically in the initial or final

step phases of the autotune algorithm), the process will fail, producing an error message indicating the fault. Given that the autotune algorithm uses an open loop temperature step, large temperature steps are more likely to cause a protection limit to be exceeded, usually a current or voltage limit. If a large temperature step is desired, use a smaller tuning step by making the start temperature closer to the stop temperature. For example, rather than a step of 25°C to 70°C, try a 65°C to 70°C step.

Managing Multiple Sets of PID Coefficients

A successful autotune session provides two sets of coefficients: one for minimum temperature overshoot, one for minimum temperature settling time. A working set of PID values is used for temperature control. For the Model 2510-AT to use the autotune results, one set of PID coefficients must be transferred to the working set. Step 3 in the “SCPI Programming” section shows how to transfer a chosen set of PIDs from the autotune session to the operational set. Note that all three sets of coefficients are stored in volatile memory, so these coefficients will be lost if there’s a power cycle or instrument reset. Using the command in Step 7 will save the operational set to an instrument setup. To retain the two sets of PIDs from the autotune session, transfer them to the operational set, then save in an instrument setup as shown in Step 7. Take care to note the save setup number of each PID set. It is also possible to save them by recording the values after querying the instrument using the commands in Step 2.

PID Tweaking and PID Terms

The Ziegler-Nichols algorithm used by the autotune process provides good, but not perfect, PID values. If the autotune algorithm does not produce the desired response, use the numbers created by the autotune algorithm as a starting point and work from there to create the desired performance. The following is an intuitive explanation of what each term does:

Kp (Proportional gain constant)—This is the number that “pushes” the system to its final value. Lower numbers create a slower response; larger numbers help increase the response speed. Excessively large values can cause the system to oscillate and/or become unstable.

Ki (Integral gain constant)—This number is responsible for how fast the system settles to its final value, as well as the amount of overshoot in the response. Low numbers create a long settling tail with minimal overshoot; large numbers settle much more quickly but with greater overshoot. Excessively large values can cause system to become unstable (and probably oscillate).

Kd (Derivative gain constant)—This number restricts rapid system temperature movements. Small values allow the system temperature to change essentially without restriction. Large values place greater restrictions on rapid temperature

movements. Modify this number to control how the system responds to large temperature changes.

Typical Sources of Error/Limitations

Common Problems

A temperature overrange (ORR) may occur because the force output wiring is reversed. This may be easily observed from the Model 2510-AT’s front panel. If the present temperature is moving farther away from the setpoint for several seconds before the ORR status indicator appears, the outputs F+ and F– probably need to be swapped. The Model 2510-AT assumes that a positive voltage/current *heats* the DUT (see *Figure 4*).

Note that the autotune PID coefficients, and protection limits are stored in volatile memory. To maintain the desired settings, save the instrument configuration. See Steps 7 and 8 in the section on SCPI programming for details.

Error Messages

If the autotune process fails, an error message will be displayed briefly. This error message can be retrieved from the system error queue with these commands:

```
send (kth2510AT, "stat:que?", status)
                                     'Query error queue
enter(strerrmsg, 30, length, kth2510AT, status)
                                     'Retrieve error message
```

Error +831, Autotune - Ambient Unstable

This error message indicates the ambient temperature, measured throughout of the autotuning process, was too unstable (rough temp variability?). This error may be eliminated by blocking any air currents from the area around the fixture and insulating the DUT/TEC fixture even more than it is already.

Error +816 Insufficient Temperature Step

This error message typically indicates the system Tau is longer than specified, resulting in a temperature that did not reach the target (i.e., final) temperature. If tuning a fixture, start with Tau = med. Potential causes are that the TEC connection has an open circuit or that the Peltier gain (Volts/°C) is too low, or the thermal mass of the fixture is too large.

Error –230 Data Corrupt or Stale

If received while attempting to transfer autotune PID coefficients, this error indicates that the autotune session was not successful.

Autotuning Fixtures (Long Tau) Problems

The initial portion of the autotune algorithm determines when the system temperature is stable. The longer Tau systems require a longer sampling time to determine when the system temperature is stable. This long measurement time means that ambient temperature fluctuations can have a negative effect on temperature measurement. If the temperature is changing or drifting,

error “831 Autotune—Ambient Unstable” may occur. Eliminating temperature fluctuations will help eliminate this error condition. If the fluctuations in the ambient environment cannot be reduced, the thermal insulation of the DUT and fixture will minimize these effects. The autotune function can accommodate Tau values between one and 450 seconds.

Algorithm Limitations

Several limitations inherent to the Model 2510-AT’s autotune function can cause it to fail:

1. A temperature step less than at least 3°C.
2. A system Tau time of less than one second or greater than 450 seconds.
3. A system Lag time greater than 0.6 · Tau.
4. Ambient temperature outside the range of the HILIM and LOLIM values.
5. Ambient temperature movements of greater than $\pm 0.010^{\circ}\text{C}$ during the autotune sequence.
6. Noisy temperature measurements. Air currents around the DUT or temperature sensor may cause the system temperature to wander (i.e., not settle out to a final value). Also, poor thermal contact between the temperature transducer and the DUT can cause oscillation or other system-related problems.
7. Reaching any temperature, current, or voltage protection limit during the initial or final autotune voltage step test.
8. A TEC (Peltier element) resistance that’s greater than 80 Ω . Use the AC Ohms feature of the Model 2510-AT to determine the TEC resistance.
9. Testing devices with resistive heaters. The autotune algorithm was not designed to accommodate resistive heaters.

Specifications are subject to change without notice.

All Keithley trademarks and trade names are the property of Keithley Instruments, Inc.
All other trademarks and trade names are the property of their respective companies.



Keithley Instruments, Inc.

Sales Offices:

BELGIUM:
CHINA:
FINLAND:
FRANCE:
GERMANY:
GREAT BRITAIN:
INDIA:
ITALY:
JAPAN:
KOREA:
NETHERLANDS:
SWEDEN:
SWITZERLAND:
TAIWAN:

28775 Aurora Road • Cleveland, Ohio 44139 • 440-248-0400 • Fax: 440-248-6168
1-888-KEITHLEY (534-8453) • www.keithley.com

Bergensesteenweg 709 • B-1600 Sint-Pieters-Leeuw • 02-363 00 40 • Fax: 02/363 00 64
Yuan Chen Xin Building, Room 705 • 12 Yumin Road, Dewai, Madian • Beijing 100029 • 8610-6202-2886 • Fax: 8610-6202-2892
Tietäjantie 2 • 02130 Espoo • Phone: 09-54 75 08 10 • Fax: 09-25 10 51 00
3, allée des Garays • 91127 Palaiseau Cédex • 01-64 53 20 20 • Fax: 01-60 11 77 26
Landsberger Strasse 65 • 82110 Germering • 089/84 93 07-40 • Fax: 089/84 93 07-34
Unit 2 Commerce Park, Brunel Road • Theale • Berkshire RG7 4AB • 0118 929 7500 • Fax: 0118 929 7519
Flat 2B, WILLOCRISSA • 14, Rest House Crescent • Bangalore 560 001 • 91-80-509-1320/21 • Fax: 91-80-509-1322
Viale San Gimignano, 38 • 20146 Milano • 02-48 39 16 01 • Fax: 02-48 30 22 74
New Pier Takeshiba North Tower 13F • 11-1, Kaigan 1-chome • Minato-ku, Tokyo 105-0022 • 81-3-5733-7555 • Fax: 81-3-5733-7556
2FL., URI Building • 2-14 Yangjae-Dong • Seocho-Gu, Seoul 137-130 • 82-2-574-7778 • Fax: 82-2-574-7838
Postbus 559 • 4200 AN Gorinchem • 0183-635333 • Fax: 0183-630821
c/o Regus Business Centre • Frosundaviks Allé 15, 4tr • 169 70 Solna • 08-509 04 679 • Fax: 08-655 26 10
Kriesbachstrasse 4 • 8600 Dübendorf • 01-821 94 44 • Fax: 01-820 30 81
1FL., 85 Po Ai Street • Hsinchu, Taiwan, R.O.C. • 886-3-572-9077 • Fax: 886-3-572-9031

Equipment List

- Model 2510-AT Autotuning TEC SourceMeter® instrument
- KPCI-488 IEEE-488.2 Interface for PCI Bus (or other GPIB/IEEE-488 interface card)
- 7008-3 IEEE-488 (GPIB) Cable 3 ft (0.9 m)
- 7009-5 RS-232 Cable (for applications not requiring GPIB speed or expansion capabilities)
- Extra Connector CS-846 (optional, one CS-846 included with 2510/2510-AT)
- 2510-CAB (optional, depending on test cabling requirements)

Related Documentation

For Model 2510-AT applications in L-I-V testing, refer to “High Throughput DC Production Testing of Telecommunications Laser Diode Modules” (Number 2214)

Example Program

Keithley has developed an example Visual Basic program to configure and launch an autotune session with the Model 2510-AT. This free program can be downloaded from the Keithley website: <http://www.keithley.com>

Reference

Karl J. Åström, Björn Wittenmark, *Adaptive Control*, Addison Wesley, 1995.